



**"Quality Endures"**

www.esielectro.com

electroserviceindia@gmail.com

9903993911 / 8981089077

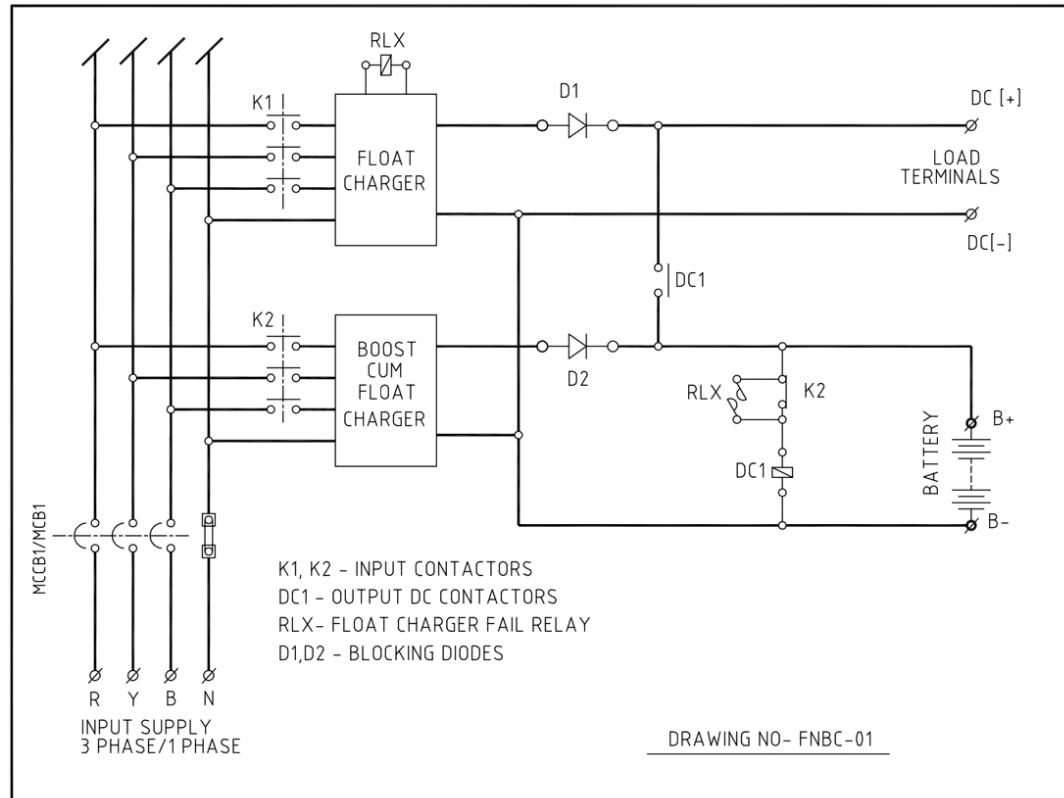

- **Normally float charger feeds load and trickle charges the battery through DC contactor contact DC1 since DC contactor is energized by battery bank. Float rectifier operates in constant voltage mode and maintains a constant voltage across load terminal (settable between 2.0 and 2.3 V / cell).**
- **During power outage battery feeds load through the same path (closed DC1) and maintains uninterrupted supply at DC output terminal.**
- **Normally boost charger (or boost cum float charger) remains OFF. If battery voltage goes down after heavy discharge, then boost charger contactor K2 is switched ON by battery under voltage sensing relay and boost charger charges battery in constant current/voltage mode.**
- **When boost charger is switched ON by K2, DC contactor DC1 is de-energised by K2 interlock thus eliminating the possibility of appearance of high DC voltage of battery (when charged beyond 2.3 V / cell) across the sensitive load.**
- **Now float rectifier feeds load in constant voltage mode and boost charger charges battery. At this stage if power fails, battery feeds the load as soon as DC contactor picks up. But total no break supply is maintained at the load through tap cell diode, connected at 80% cell of the battery bank.**
- **Battery voltage increases with charge and when it reaches a preset level, the battery over voltage relay is activated, which consequently switches OFF K2. The system goes back to normal mode of operation, that is float rectifier feeds the load and trickle charges the battery while boost rectifier remains OFF.**
- **Boost charger can also be switched ON manually for initial and equalizing charging.**
- **In the event of failure of float charger float charger fail relay RLX is energized and switches ON boost-cum-float charger in float mode (that is in CV mode). DC1 is also energized so that boost charger charges the battery and feeds the load. Float charger fail alarm is activated for service of the float rectifier.**

TOPOLOGY:

# FLOAT AND STANDBY BOOST CUM FLOAT BATTERY CHARGER